

Dimensions

■ Front View

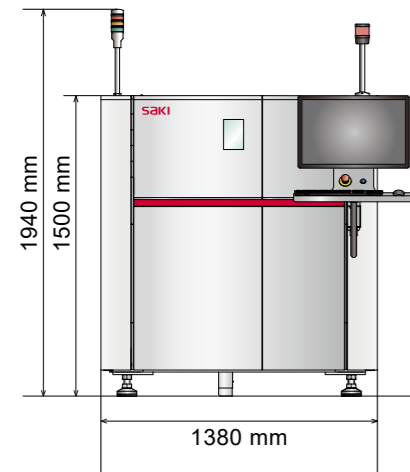

■ Side View

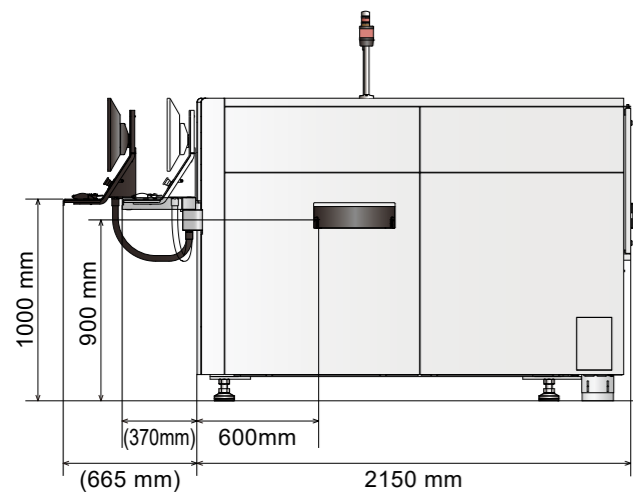

Hardware / Function Specifications

Model	3Xi-M110
Resolution	10μm-30μm
Target PCB Size mm (in.)	50W x 120L - 360W x 330L (1.97W x 4.73L - 14.17W x 12.99L) 50W x 120L - 360W x 510L ※ (1.97W x 4.72L - 14.17W x 20.07L)※
PCB Thickness	0.8mm - 4.0mm (0.031-0.157 in.)
PCB Warp	2mm (0.08 in.) or less
PCB Clearance	TOP : 60mm (2.36 in.) Bottom : 40mm (1.57 in.)
Inspection Categories	Chip Type Parts, Diodes, Tantalum Capacitors, Aluminum Electrolytic Capacitors, Module chips, Transistors, Power Transistors, Connectors, QFP, SOP, CSP, QFN, and BGA
Detector	Flat Panel 14bit 3M Pixel
X-ray Tube	110kV 30W, Closed X-ray Source
X-ray leakage	0.5μSvh or less
Conveyor Method	Flat belt transfer
Conveyor Height	880-920mm (34.65-36.22 in.)
Width Adjustment	Auto Width Adjustment
Operating System	Windows 10 IoT Enterprise2019 EMB 64bit (Microsoft)
Electric Power Requirement	Three - Phase ~200 +/-10%, 50/60Hz
Power Consumption	4.2kVA
Air Requirement	0.5 MPa, 20 L/min(ANR)
Usage Environment	15°C - 30°C / 15 - 80%RH (Non-condensing)
Noise Level	70.0dB or less
Dimensions W x D x H (Main body)	1380 × 2150 × 1500mm (54.34 x 84.65 x 59.06 in.)
Weight (Main body)	Aprox. 3,100 kg (6834.34 lbs)

※ with applying the two-step imaging option

Inline 3D-CT Automated X-ray Inspection System for Printed Circuit Board Assemblies (PCBAs).

3Xi-M110



saki Saki Corporation

Headquarters
DMG MORI Tokyo Digital Innovation Center
3-1-4, Edagawa, Koto-ku, Tokyo, 135-0051, Japan
TEL: +81-3-6632-7910 FAX: +81-3-6632-7915

Global Network
<https://www.sakicorp.com/en/>

The Ultimate in Inspection Speed and Accuracy.

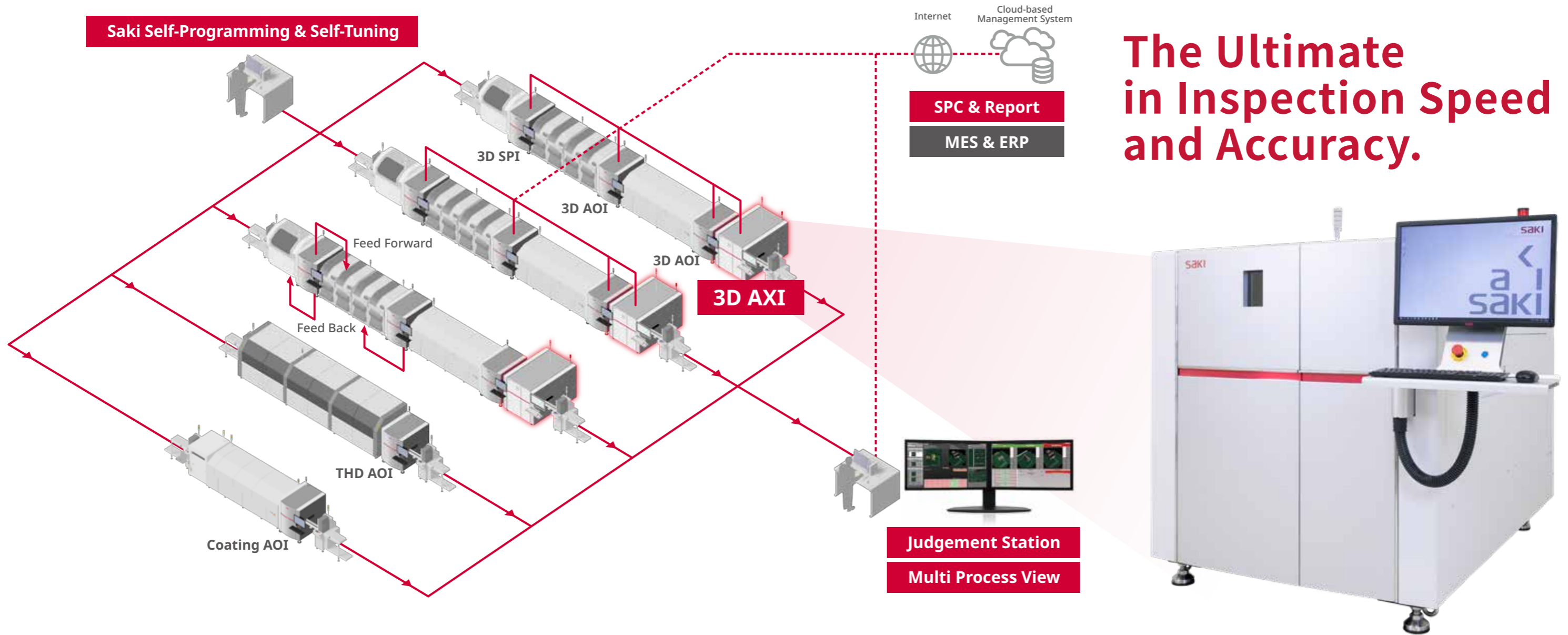

Merit 1 Saki's planar CT technology captures hard-to-find defects

- The 3Xi-M110 ensures hidden solder joint quality for bottom-electrode packages such as BGAs, LGAs, and QFNs
- PCT provides precise volumetric measurements and shape reconstruction to find voids, head-in-pillow (HiP), and other defects that are extremely difficult to identify

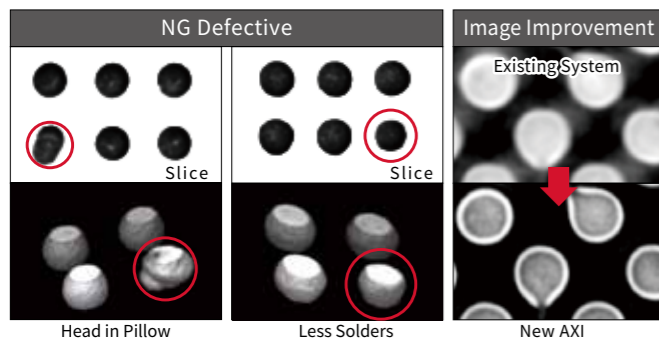

Merit 2 Reduced x-ray exposure

- Revolutionary x-ray tube reduces x-ray exposure up to 70% by powering on x-rays only at the moment of image capture
- Exposure dose simulator lets the user monitor the radiation dose
- The method and magnification for releasing the x-rays can be set
- Periodic maintenance and spare parts are not required
- Built-in monitoring system reports when the tube needs replacing

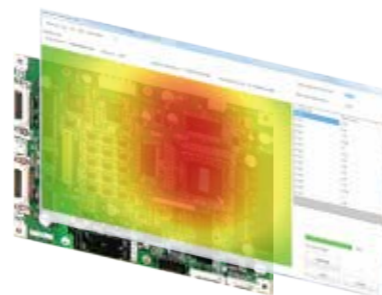

Merit 3 Lightweight, rigid structure in a small footprint

- 40% lighter hardware platform (3,100kg) and a 25% smaller footprint (1,380mm width)
- Saves floorspace, is easily installed, and improves production-line operability
- Light, but rigid cast iron frame for stable operation and accuracy
- Optimized imaging range for PCBs up to 360 x 330mm (W x L)
- 2-step image capture is available for larger 360 x 510mm (W x L) boards

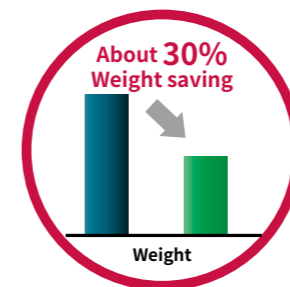
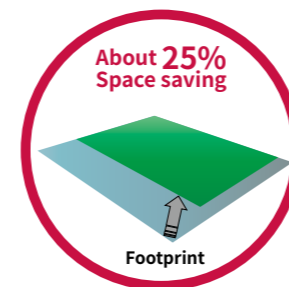

Merit 4 High accuracy and speed

- Reliable and consistent positioning accuracy and speed
- Double motor-driven system and high-precision linear scale by Magnescale assures precision and power
- Optimized Planar Computed Tomography (PCT) technology algorithm improves image capture speed by 30%, reducing takt time

